

PRODUCT DATA SHEET

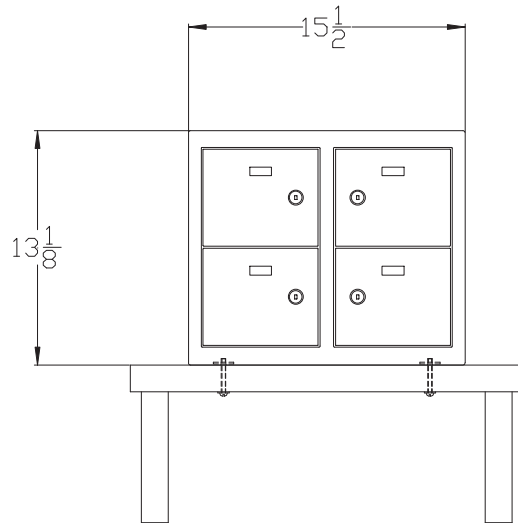

COMMANDER PISTOL LOCKER 2x2 (Desk / Shelf Mount)



Product Code: STL22-151213

General Description: Factory assembled welded steel locker with four (4) patron doors, foam padded shelves, horizontal configuration 2-wide x 2-high.

Dimensions (W x D x H):
15-1/2 in. (394 mm) x 12 in. (305 mm) x 13-1/8 (333 mm)

Door Opening (W x H): 6-3/8 in. (136 mm) x 5-3/8 in. (162 mm)

Material: Frame & door 16 ga.; shelves & body 18 ga.

Construction: Welded steel, no exposed rivets, smooth outside surfaces, doors flanged with welded corners, shelves weld secured to body. Hinges continuous, concealed, welded to frame and bolted to door. Pry protection guard conceals cam.

Locking System: Two (2) keys per compartment, chrome plated brass cam key locks, brass lock housing and cylinder, drill resistant, 100 million possible key combinations, proprietary key blank, lock and key replacement or exchange by Precision Locker Company only. Optional master keyed locks also available.

Finish: Powder coat paint finish. Standard color combinations: 2-tone blue, 2-tone bronze, 2-tone charcoal. Architectural color samples are available.

Installation: Desk/shelf mount is recommended. Pre-drilled mounting holes in rear of unit for securing to wall; pre-drilled holes for vertical and horizontal ganging. Owner to provide fasteners, anchors, brackets and other hardware of type and size appropriate for type of substrate.

Weight: 26 lbs.

Precision Locker Company
Jamestown, NY
1-877-243-5094
www.precisionlocker.com